

# February 10, 2016 Advisory Council Meeting Materials Packet

## Table of Contents

<b>Meeting Agenda .....</b>	<b>1</b>
<b>Agenda Item 3: Licensing-Enforcement Statistics – October-December 2015 .....</b>	<b>3</b>
<b>Agenda Item 5: Regulatory Update.....</b>	<b>5</b>
<b>Agenda Item 8: Service Contract Working Group 2016 Plan .....</b>	<b>8</b>
<b>Agenda Item 13: TB 117-2013 Barrier Research Study Update.....</b>	<b>11</b>
a. Small Scale Testing Procedure (Final) .....	12
b. Small Scale Testing Procedure Comments Summary and Responses .....	27
<b>Agenda Item 14: SB 1019 Compliance Statistics .....</b>	<b>29</b>
<b>Agenda Item 16: Public Comment Period: Presentation on TB 133 by Robert Hupe.....</b>	<b>31</b>

*Note: Meeting Material Page numbers are underlined and found at the bottom center of each page. Additionally, the Bureau's 2016 Outreach Plan will be a separate document that will be referenced during Agenda Item 6.*



**BUREAU OF ELECTRONIC AND APPLIANCE REPAIR  
HOME FURNISHINGS AND THERMAL INSULATION**  
4244 S. Market Ct, Suite D, Sacramento, CA 95834-1243  
P (916) 999-2041 F (916) 921-7279 / www.bearhfti.ca.gov

**ADVISORY COUNCIL MEETING  
NOTICE & AGENDA  
Teleconference Meeting  
Wednesday, February 10, 2016, 9:00 a.m.**  
Bureau of Electronic and Appliance Repair,  
Home Furnishings and Thermal Insulation

**Meeting Locations**

*(Please note: interested parties can attend the meeting in-person at either location or may use the teleconference information to call in.)*

Bureau of Automotive Repair Field Office  
1450 Iowa Avenue, Suite 150  
Riverside, CA 92507

BEARHFTI Headquarters  
4244 South Market Court, Ste. D  
Sacramento, CA 95834

**Teleconference Phone Number: 866-842-2981  
Participant Passcode #: 4598662**

**Advisory Council Members**

Sharron Bradley, Industry (HFTI)  
Burt Grimes, Industry (HFTI)  
Judy Levin, Public (HFTI)  
Joanne Mikami, Public (EAR & HFTI)  
David Spears, Industry (EAR)  
David Yarbrough, Industry (HFTI)

Donald Erwin, Industry (EAR)  
Timothy Hawkins, Industry (EAR)  
Donald Lucas, Public (HFTI)  
Leonard Price, Public (EAR)  
David Velasquez, Industry (EAR)

Unless noticed for a specific time, items may be heard at any time during the period of the Council meeting. The Bureau welcomes and encourages public participation in its meetings. The public may take appropriate opportunities to comment on any issue before the Bureau at the time the item is heard. If public comment is not specifically requested, members of the public should feel free to request an opportunity to comment.

**General Bureau Business Agenda Items**

1. Welcome
2. Bureau Administrative Update
3. Licensing & Enforcement Report
4. Department of Consumer Affairs Legislative Update
5. Regulations Update
6. Bureau 2016 Outreach Plan
7. Public Comment on Items not on the Agenda

***Electronic and Appliance Repair Agenda Items***

8. Service Contract Working Group Update
9. Appliance Repairs in Residential Complexes
10. Public Comment on Electronic and Appliance Repair Items not on the Agenda

**Recess until 1:00 p.m.**

---

**The Advisory Council will reconvene at 1:00 p.m.**

***Home Furnishings and Thermal Insulation Agenda Items***

11. Home Furnishings Retail Advertisement Regulations Update
12. Operations Update – Importer Inspections
13. Technical Bulletin 117-2013 Update
14. SB 1019 Implementation Update
15. Thermal Insulation Program and Regulatory Update
16. Public Comment on Home Furnishings and Thermal Insulation Items not on the Agenda
17. Adjournment

**This meeting facility is accessible to the physically disabled. A person who needs a disability-related accommodation or modifications in order to participate in the meeting may make a request by contacting Victoria Hernandez at (916) 999-2055 or, for the hearing impaired, TDD (800) 326-2297; or by sending a written request to the Bureau at 4244 South Market Court, Suite D, Sacramento, CA 95834-1243, Attention: Victoria. Providing at least five working days' notice before the meeting will help ensure the availability of accommodations or modifications.**





LICENSING / ENFORCEMENT STATISTICS  
October – December 2015

<b><i>EAR Registrations</i></b>	October 2015	November 2015	December 2015
Appliance Service Dealer	2,504	2,548	2,554
Electronic Service Dealer	5,055	5,059	5,030
Combination Electronic/Appliance Service Dealer	488	488	488
Service Contract Administrator	43	43	44
Service Contract Seller	10,297	10,397	10,519
<b><i>Total EAR Registrations</i></b>	<b>18,387</b>	<b>18,517</b>	<b>18,635</b>

<b><i>HFTI Licenses</i></b>	October 2015	November 2015	December 2015
Furniture Retailers	2,229	2,247	2,243
Bedding Retailers	1,598	1,572	1,612
Furniture & Bedding Retailers	11,764	11,760	11,677
Custom Upholsterers	490	486	479
Supply Dealers	127	129	131
Importers (includes overseas Manufacturers)	4,385	4,456	4,463
Manufacturers	1,463	1,462	1,464
Sanitizers	15	15	15
Wholesalers	150	150	152
Thermal Insulation Manufacturers	117	121	119
<b><i>Total HFTI Licenses</i></b>	<b>22,338</b>	<b>22,398</b>	<b>22,355</b>

***Bureau Investigations and Enforcement***

<b><i>BEARHFTI</i></b>	October 2015	November 2015	December 2015	Average*
Complaints Received	253	155	192	218
Investigations Opened	127	67	105	99
Citations Issued	124	88	90	116
AG Cases Initiated/Pending	5	5	5	5

\*Six month average

## Agenda Item 5: Regulatory Update

Program	Subject	Issue	CCR Section(s)	Priority	Status
HFTI	Licensing Fee Increases	Raise HFTI licensing fees following passage of AB1175	4 CCR 1107	High	In Departmental Review
EAR	Citation Fee Cap Increase	Align citation fees with allowed fines in general statute	16 CCR 2771	High	In Departmental Review
EAR	Service Contract Application	Revise to no longer require in regulation	16 CCR 2756	High	In Departmental Review
HFTI	Advertising	Update advertising regulations to address current market practices	4 CCR 1300 et seq.	High	Research and discussion phase - Retailer Surveys In Progress
HFTI	Thermal Insulation	Revise to make language current	Title 24, Part 12	High	Bureau currently seeking informal comment from stakeholders on draft

HFTI	Citation Fee Cap Increase	Align citation fees with allowed fines in general statute	4 CCR 1383.2	Medium	Bureau currently drafting
EAR	Disciplinary Guidelines	Update with additional probationary provisions	16 CCR 2775	Medium	Bureau currently drafting
HFTI	Disciplinary Guidelines	Update with additional probationary provisions	4 CCR 1379	Medium	Bureau currently drafting
EAR	Advertising	Update advertising regulations to address current market practices and to require registration numbers in advertisement	16 CCR 2751 et seq.	Medium	Research and discussion phase
HFTI	Labeling Updates	Revise to make language current, add plumage label example	4 CCR 1125 et seq.	Medium	Research and discussion phase
HFTI	Laboratory Terminology	Update to include current materials	TBD	Medium	Research and discussion phase

EAR	Obsolete technology	Remove references to picture tube grading and other technology that is no longer relevant	16 CCR 2727 et seq.	Low	Bureau currently drafting
HFTI	TB 133 Changes	Review prior drafts for relevancy	4 CCR 1374	Low	Under consideration
HFTI	Water Beds	Remove and update references	TBD	Low	Under consideration

Program	Subject	Issue	CCR Section(s)	Priority	Status
HFTI	Plumage	Update cleanliness requirements, evaluate oxygen standard, update citation regulations to remove obsolete fine authority for section 1192.1, and add fine authority for section 1193.	4 CCR 1193(h), 1383.2	Low	Under consideration
HFTI	Damaged Feathers	Assess current damaged feather failure rate and evaluate changing current standard to sliding scale	4 CCR 1193(b), 1193(c)	Low	Under consideration
HFTI	Mattresses	Update flammability regulations to include smoldering resistance requirements of 16 CFR 1632	TBD	Low	Under consideration
HFTI	Obsolete Regulations	Repeal obsolete language within the general provisions and citation regulations	4 CCR 1114-1121, 1383.2	Low	Under consideration
EAR	Registration Renewals	Update registration renewal regulations and applications to include criminal history inquiry	TBD	Low	Under consideration



Agenda Item 8: Service Contract  
Working Group 2016 Plan

## Service Contract Working Group Plan

- Tentative Schedule/Work Plan
  - Week of 2/29/16 – Discussion, identify areas for report
  - Week of 5/31/16 – Review and revise, add items, as necessary
  - Week of 8/1/16 – First rough draft of report
    - Review by group, additional revisions
  - Week of 9/1/16 – Second draft of report
    - Review by group and finalize
  - 10/13/16 – Final draft to present at 10/13/16 Advisory Council Meeting
- Recruitment of consumer members
- Define areas for report including
  - History of Bureau regulation
  - Summary of regulated products/unregulated products
  - Other state regulation
  - Jurisdictional division between the Bureau and the California Department of Insurance
  - Types of offerings
  - Required terms, provisions and conditions in regulated service contracts
  - Financial backing alternatives
  - Bureau enforcement options
  - Comparison of National Model Act to current California regulation
  - Industry trends, marketing and offerings – vision of the future
  - Consumer perception of service contracts
  - Registration requirements for internet-based companies
  - Recommendations for regulation changes
  - Other areas identified
- Areas of discussion
  - Industry awareness of California requirements
  - Relevancy of regulation to current marketplace
    - What products should be regulated?
    - Inconsistent cancellation provisions based on product type
  - Consumer awareness of coverage and exclusions
  - Consumer recourse (both insured and non-insured contracts)
  - Ensuring contracts have value
  - Arbitration clauses
  - Adhesion clauses
  - “Blanket” contracts
  - Administrator awareness of sellers offering their contracts

- Reference Materials
  - Legislative History
  - 1999 Survey (will be available on web because of size)
  - National Model Act
  - Relevant California Business and Professions Code, Code of Regulations and Civil Code
  - Excerpts from CPS Report (survey includes consumer responses regarding service contracts)
  - Service Contracts Information Flyer

Agenda Item 13: TB 117-2013 Barrier  
Research Study Update

**State of California  
Department of Consumer Affairs**

**BUREAU OF ELECTRONIC & APPLIANCE REPAIR  
HOME FURNISHINGS & THERMAL INSULATION  
4244 SOUTH MARKET COURT, SUITE D  
SACRAMENTO, CA 95834-1243**

**Small-Scale  
Open Flame Test for Barrier Materials**

***Requirements, Test Procedure and Apparatus for Testing the  
Open Flame Resistance of Barrier Materials***

**January 2016**

# Requirements, Test Procedure and Apparatus for Testing the Open Flame Resistance of Barrier Materials

## **Barrier Materials Component Test - Open-Fame Resistance**

**1. Scope** - This standard applies to any material in the form of battings, pads, fabrics, etc. that is used as a barrier in upholstered seating furniture. The test method can also be used for upholstery cover fabrics that are fire resistant and serve as fire barriers as well.

**2. Summary of Test Method** - The test method consists of the application of an open-flame ignition source, to the bottom side of a horizontally mounted specimen of the barrier material while a layer of standard non-fire retardant polyurethane foam is placed on the top side of the barrier material. The test specimen is situated over an opening and is sandwiched between two rigid fire-rated insulating boards supported by a metal rack. Observations of the burning behavior and patterns are used to assess the performance of the specimen under these test conditions.

**3. Significance and Use** - This test method is designed to assess the response of a barrier material test specimen to an open-flame ignition source. The test provides an indication of the resistance of the barrier material to prevent an external flame reaching the underlayment of standard polyurethane foam and igniting it.

**4. Test Apparatus and Materials** - The test apparatus, including the horizontal test frame rack and the shutter plate mechanism, is described in Annex A, Figures A1- A8.

The ignition source is a Meker-Fisher Gas Burner. The Meker-Fisher gas burner, the gas train and accessories are described in Annex B.

The Standard Polyurethane Foam (SPUF) – The standard polyurethane foam is described in Annex B of Technical Bulletin 117-2013, June 2013.

**5. Test Facility and Hazards** - The test facility, exhaust system and hazards are described in Annex C.

**6. Conditioning** - Condition test specimens and the standard PU foam prior to the test for a minimum of 24 hours at  $21^{\circ} \pm 3^{\circ} \text{C}$  ( $70^{\circ} \pm 5^{\circ} \text{F}$ ) and less than 55% RH. If the sample is taken from a finished article of furniture, conditioning does not begin until the component is removed from the furniture.

If conditions in the test area are not the same as in the conditioning area, tests should begin within 10 minutes of removal from conditioning area.

**7. Test Specimen** - Representative specimens of barrier materials shall be sampled for testing from various points in the barrier material (batting, pad, flat barrier materials, or combination of materials used as barrier). Three specimens should be prepared from different areas of the material. The specimen shall consist of a swatch of fiber batting, pad, fabric or any other type of barrier material. Cut each specimen to 250 x 250 mm (10 x 10 in) in the thickness of use.

## 8. Procedure:

- 8.1. Place the horizontal test rack in a test hood (See Annex C) that provides adequate ventilation to exhaust smoke and gases.
- 8.2. Before mounting the test specimen on the test rack prepare the gas burner ignition source. Set the gas flow to the Meker-Fisher burner as designated in Annex B. Ignite the Meker-Fisher burner and allow the flame to stabilize. Turn off the gas flow to the Meker-Fisher burner using the toggle on/off switch. Do not make any further adjustments to the gas flow. For the remainder of the test use only the on/off toggle switch. Place the bottom mounting plate on the rectangular metal retaining ring of the test rack. Make sure the plate is firmly positioned.
- 8.3. Place the barrier material test specimen on the top of the bottom horizontal mounting plate. Center the specimen flat so that the face side of the barrier material which is exposed to the heat source is towards the burner. Ensure barrier material is tight with no sagging or wrinkling.
- 8.4. Face side of the barrier test specimen is the surface of the material that is in contact with the cover fabric inside the furniture. The bottom side of the barrier is placed in contact with the interior fillings of the furniture. Many barrier materials are reversible and have no identifiable facing.
- 8.5. Place the top horizontal mounting plate over the barrier material, sandwiching the barrier material between the two mounting plates. Make sure the plate is firmly positioned.
- 8.6. Insert a piece of 5" X 5" X ½" standard polyurethane foam (SPUF) directly over the barrier material fitting snugly in the upper mounting plate rectangular opening, so that the foam contacts the barrier material at all points.
- 8.7. Close the shutter mechanism by fully inserting the shutter plate in place.
- 8.8. Place the Meker-Fisher burner in the center of the bottom plate of the test rack such that the top of the burner is positioned 4 inches (100 mm) below the center of the bottom surface of the test specimen. (Figure A-2).
- 8.9. Turn on the toggle switch and ignite the Meker-Fisher burner using a butane lighter or a spark striker.
- 8.10. After a few seconds (less than 10 seconds) pull out the shutter plate and immediately start the timing device.  
Note: Do not leave the lit burner underneath the shutter plate for more than a few seconds. Otherwise the test specimen may become preheated before ignition flame impingement.
- 8.11. Turn off the toggle switch after one minute of ignition flame impingement.
- 8.12. Remove the burner from underneath the test specimen and set it aside.
- 8.13. Continue test until all traces of flaming and smoldering have ceased. Make and record observations regarding penetration of the flame through the test specimen and/or decomposition and burning of the standard polyurethane foam.
- 8.14. When all combustion is ceased carefully remove the mounting plates and the remaining test materials off the metal test rig.
- 8.15. Thoroughly clean the mounting plates and allow them to reach room temperature before conducting the next test.

## 9. Pass/Fail Criteria

A single test specimen fails to meet the requirements of this test procedure if the standard polyurethane foam (SPUF) ignites or a visible flame (however brief) is observed above the foam:

- 9.1. A barrier material passes the test if three initial specimens pass the test.
- 9.2. If more than one initial specimen fails, the barrier material fails the test.
- 9.3. If any one of the three initial specimens fails, repeat the test on additional three specimens. If all three additional specimens pass the test, the barrier material passes the test. If any one of the additional three specimens fails, the barrier sample fails the test.

## 10. Test Report

The test report shall contain, at a minimum, the following information:

- 10.1. Name and address of the test laboratory.
- 10.2. Date of the test(s).
- 10.3. Operator conducting the test.
- 10.4. Complete description of the test materials.
- 10.5. Complete description of any procedures different from those described in this test method.
- 10.6. Observations shall be made, and included in the report, of the behavior of the specimen in response to the application of the burner, specifically noting the following:
  - 10.6.1. The time of flaming ignition of the foam when applicable.
  - 10.6.2. Extended smoldering (non-flaming) combustion.
  - 10.6.3. The condition of the standard polyurethane foam (SPUF) used in the test (e.g. 50% recovered, completely consumed, ...)
  - 10.6.4. The post-test condition of the test material.
  - 10.6.5. The total test time, i.e., time from start of ignition to the end of all combustion.
- 10.7. Statement of overall Pass/Fail results.
- 10.8. Post-test photographs of the test specimens.



## **ANNEX A**

### **Horizontal Test Apparatus**

A test rack constructed, as in Figures A-1 to A-4, shall be used to support the sample for testing. The rack shall be constructed with a 356 x 356 mm (14 x 14 in) stainless steel metal (2.4 mm (3/32 in) thick) bottom plate. At each corner of the plate, a 356 mm (14 in) long, 12 mm (1/2 in) O.D. threaded rod shall be mounted vertically to allow adjustment of a horizontal test support to various heights using threaded nuts. The test support shall consist of a fixed rectangular metal retaining ring with inside openings of 254 x 254 mm (10 x 10 in). The metal rectangular retaining ring shall have holes to act as guides for positioning threaded rods through them.

Two 300 X 300 mm (12 X 12 in.) mounting plates, as shown in Figures A1 through A3, are made of 25 mm (1 inch) thick inorganic 740-kg/m<sup>3</sup> (46 lb/ft<sup>3</sup>) nominal density calcium silicate boards. A 127 X 127 mm (5 X 5 in) opening is cut at the center of each plate. Four 12 ½ mm (½ inch) holes are made at the four corners of each mounting plate for mounting on through the threaded metal rods. The mounting plates are painted with fire resistant (high temperature) flat black paint.

Note: Other heat resistant insulation materials with physical and thermal properties similar to the calcium silicate board can also be used for the mounting plates.

#### **Shutter Mechanism**

A shutter mechanism consisting of a base shutter plate holder and a shutter plate, as shown in Figure A-5 through A-8, shall be mounted 25 mm (1 inch) below the lower retaining plate of the horizontal test apparatus.

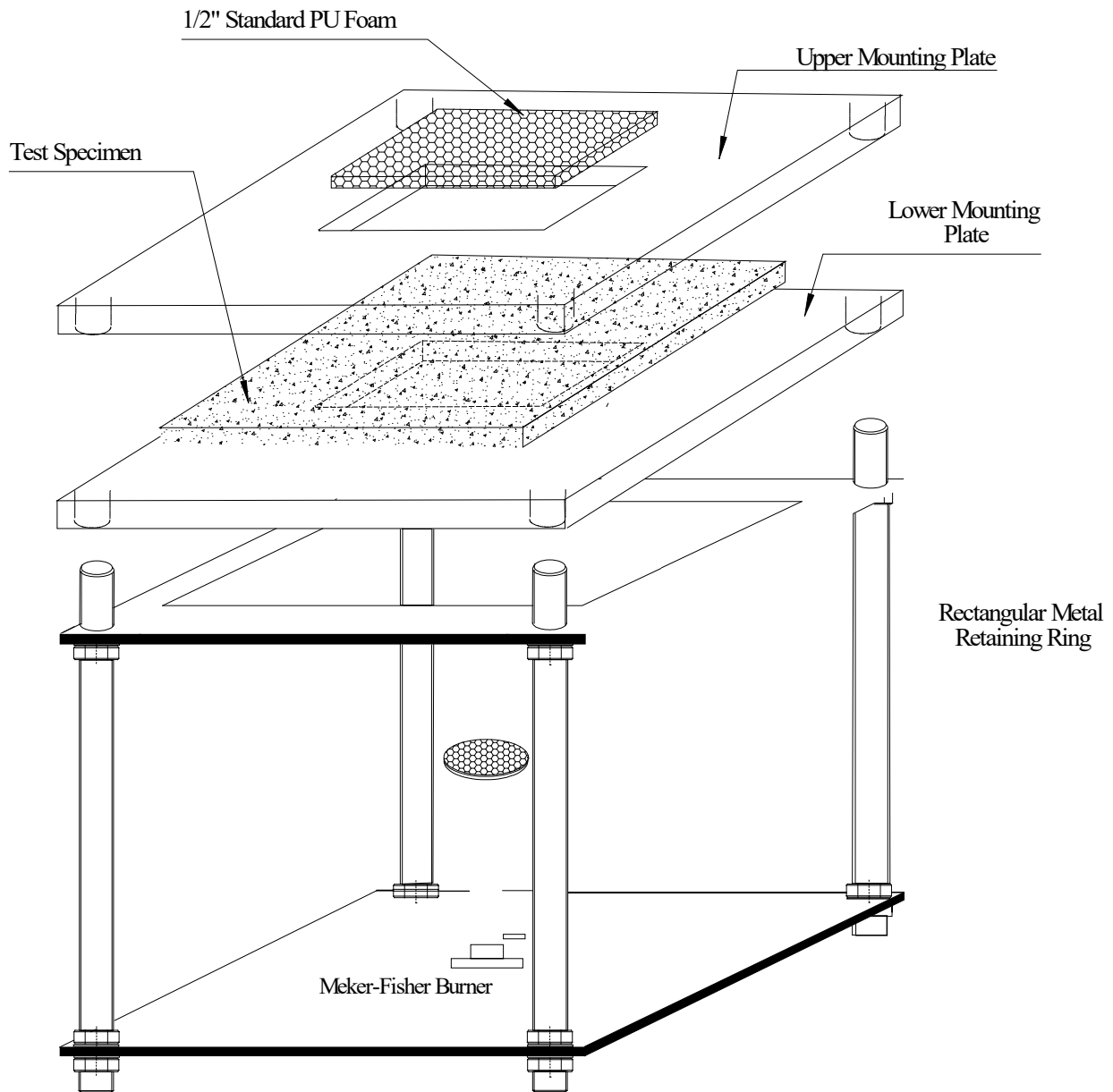

(Drawings Not to Scale)

Figure A-1. Horizontal Test Apparatus Assembly  
(Exploded View of Barrier Test Assembly)

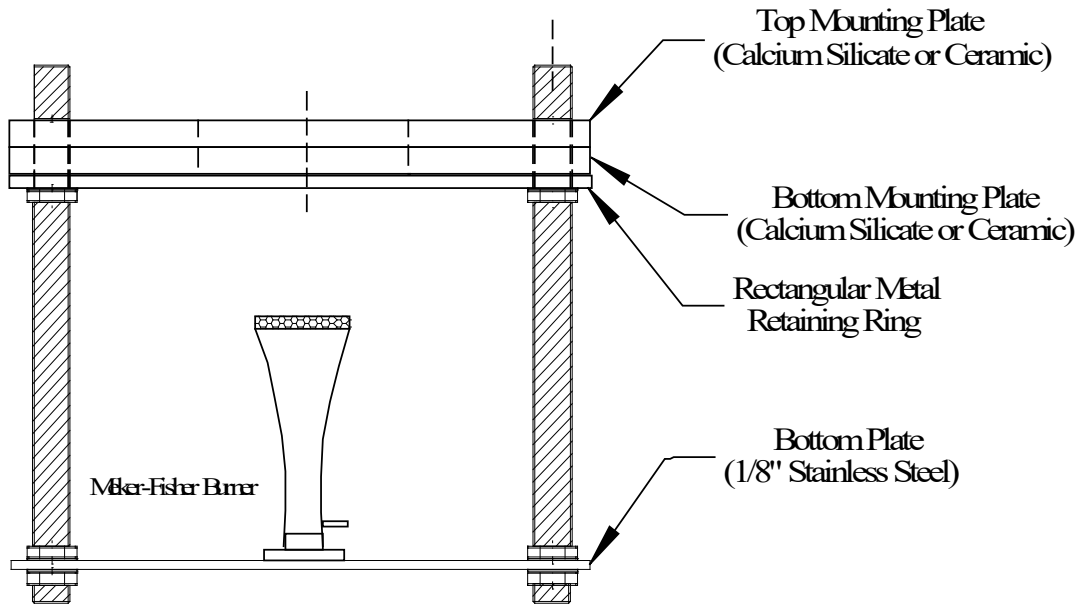

Side view of the horizontal test apparatus

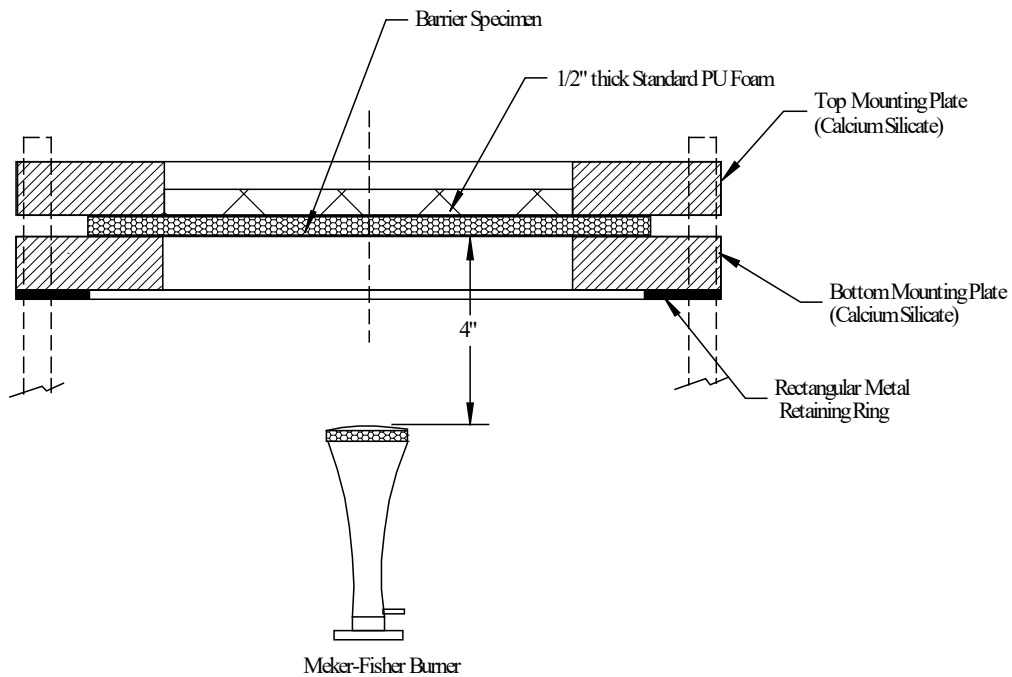

Mounting of the test specimen on the horizontal test apparatus  
(Cross Sectional Side View)

(Drawing not to scale)

Figure A-2. Horizontal Test Apparatus Assembly – Side Views

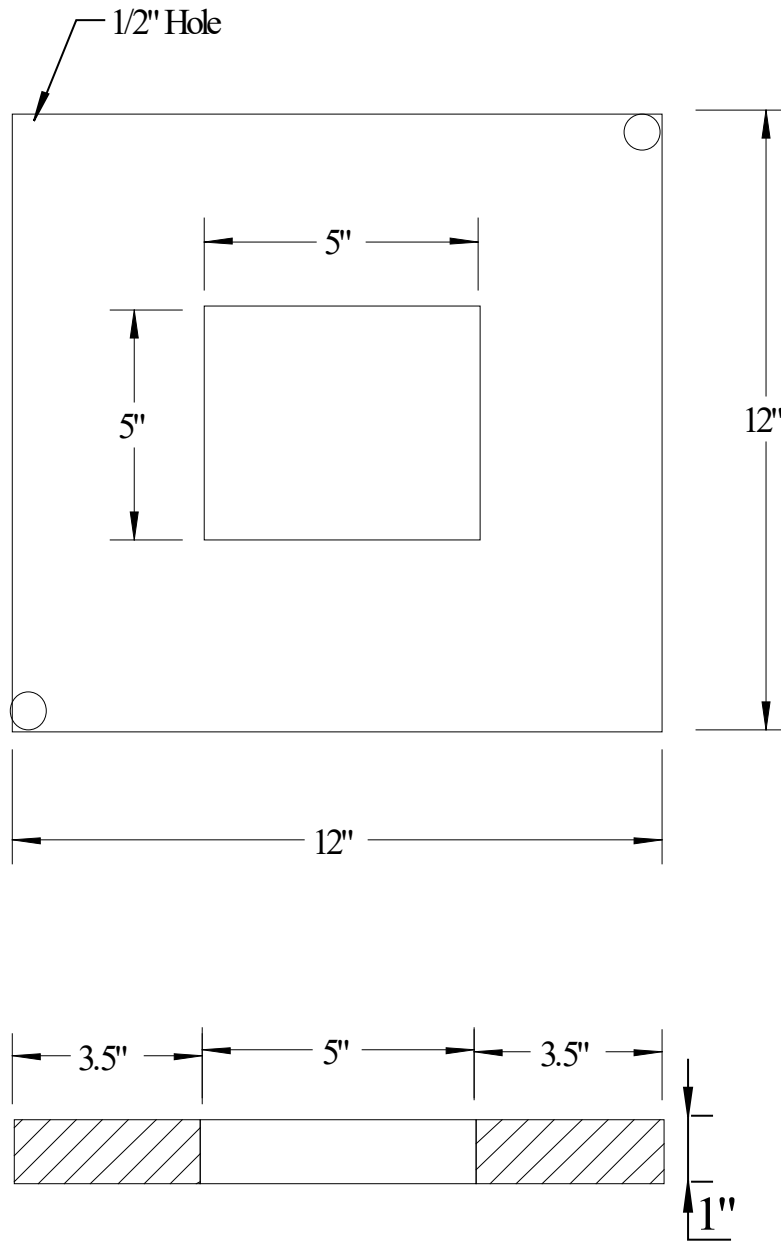

**Mounting Plates (Calcium Silicate or Ceramic)**

(Drawings not to Scale)

Figure A-3. Horizontal Test Apparatus Assembly – Mounting Plates

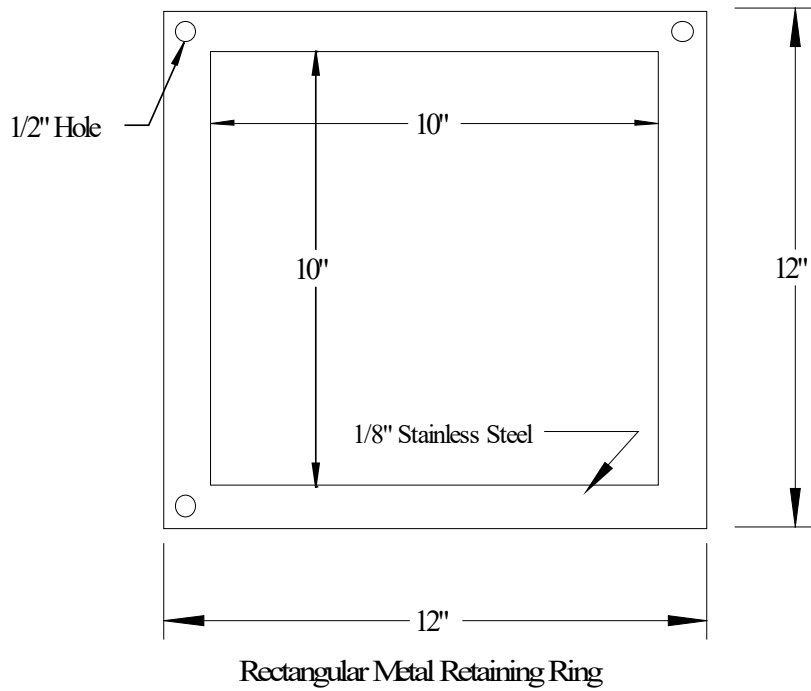
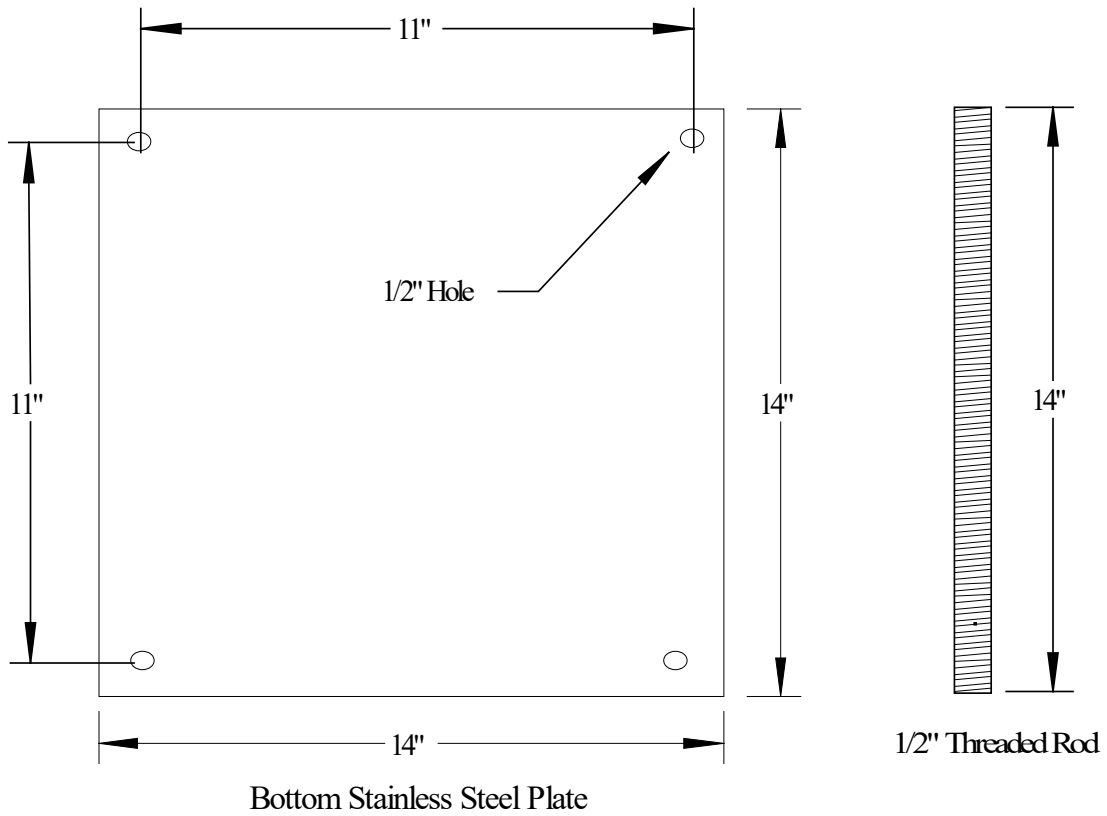

(Drawings Not to Scale)

Figure A-4. Horizontal Test Apparatus Assembly – Parts of Test Frame

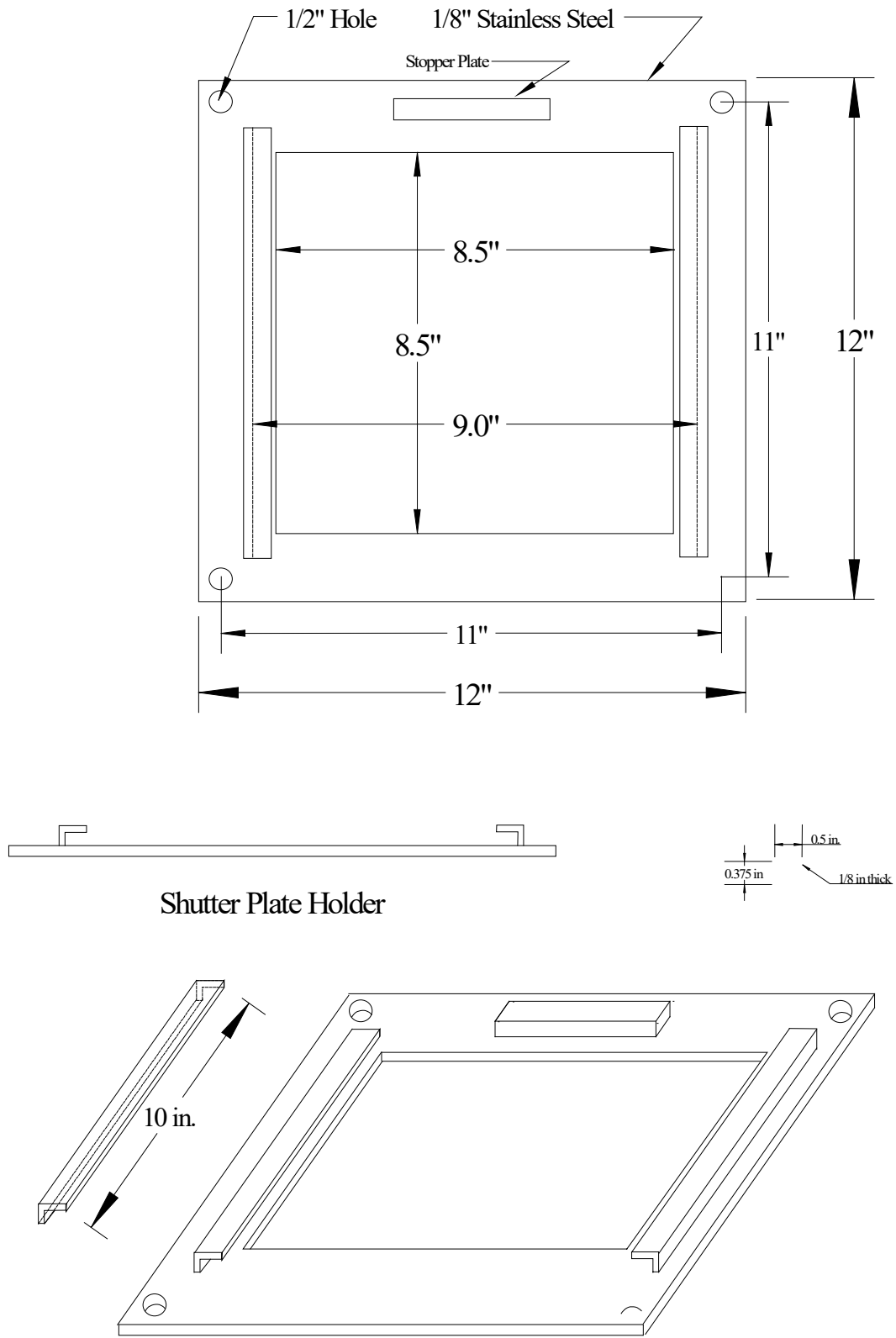

Figure A-5. Shutter Plate Mechanism

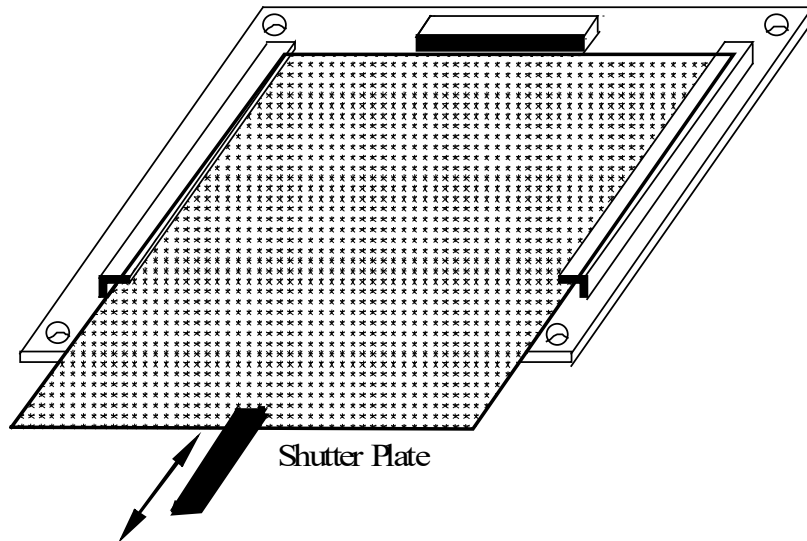
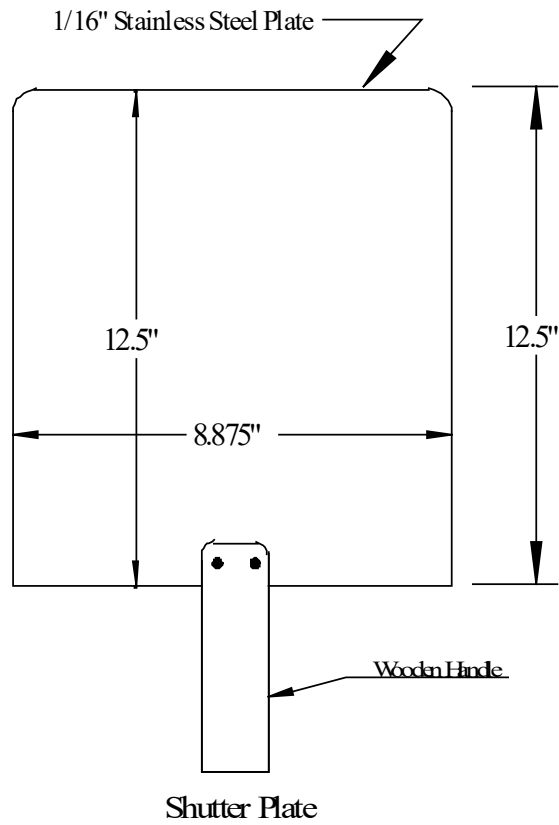

Figure A-6. Shutter Plate Mechanism

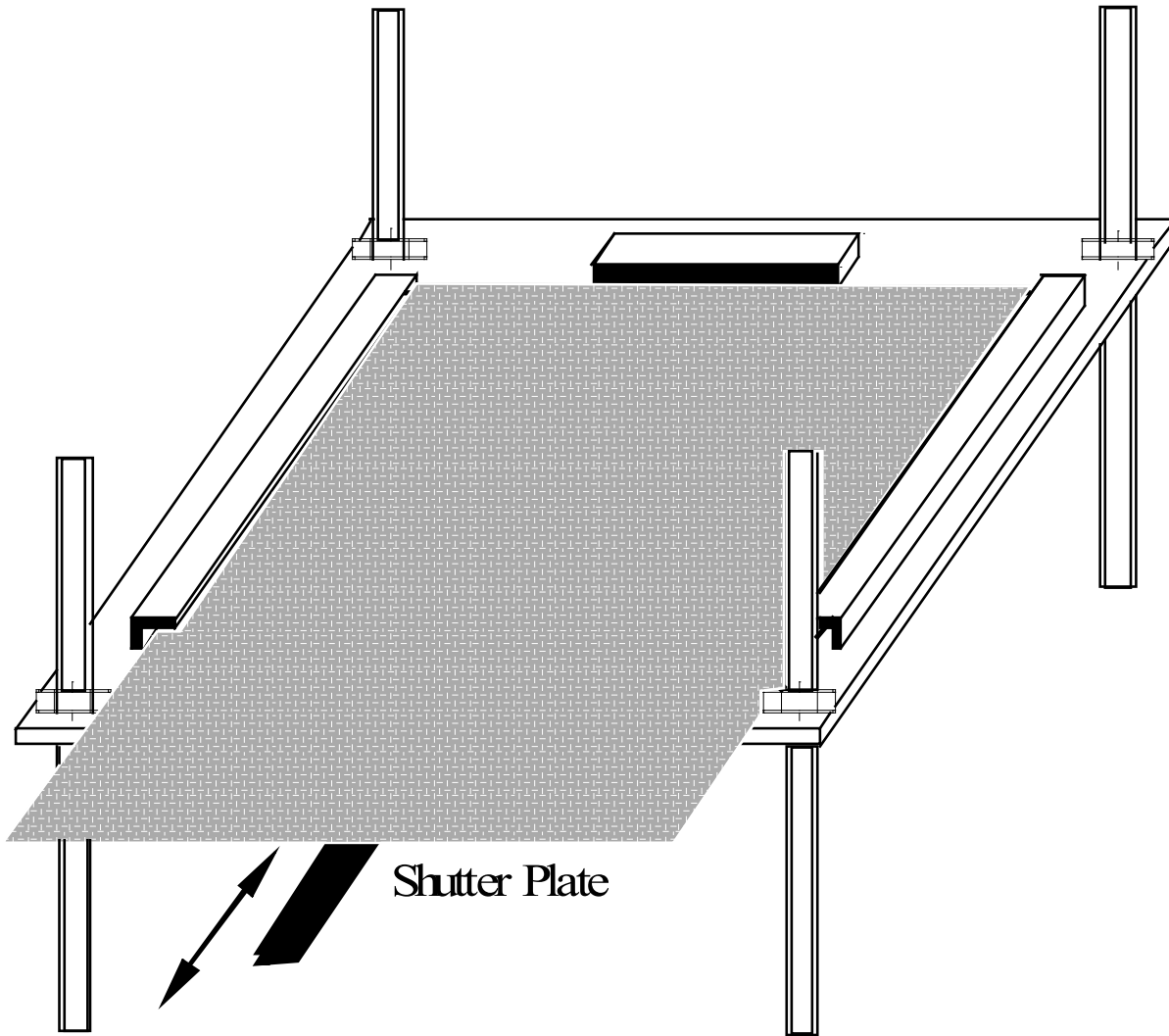

Figure A-7. Shutter Plate Placement



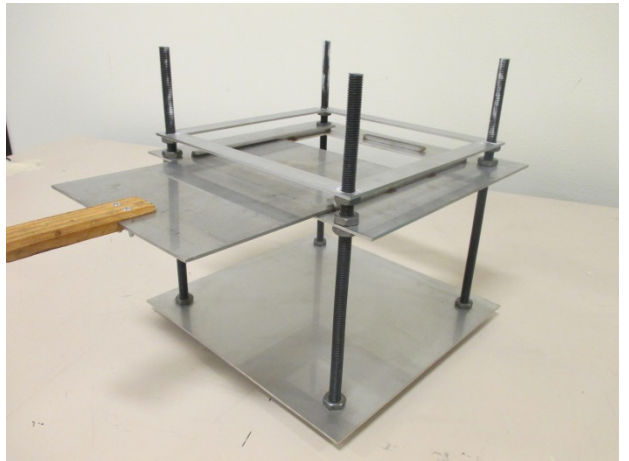
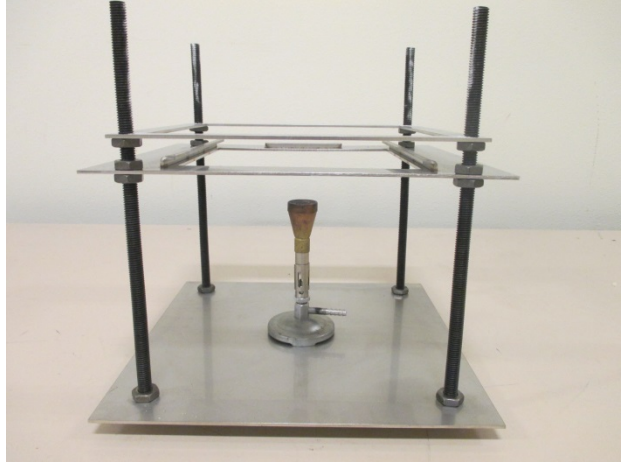

Figure A-8. Horizontal Test Apparatus Assembly with Shutter Plate Mechanism

## ANNEX B

### Ignition Source

#### Butane Gas Flame Ignition Source for Barrier Materials

- The ignition source for the barrier open flame test consists of a Meker-Fisher burner with a 32 mm (1.25 in.) diameter top and with orifice size of 1.2 mm (3/64 in.) for Butane gas.
- The flow rate of butane shall be  $500 \pm 10$  ml/min ( $0.0177$  ft<sup>3</sup>/min) at 23 °C (73 °F).

#### The Gas Train

- A gas rotameter with range to provide flow rate of equivalent to  $500 \pm 10$  ml/min ( $0.0177$  ft<sup>3</sup>/min) of air at standard conditions.
- Commercial Grade butane, 94% purity with 2-stage regulator shall be provided.
- The following items are required to connect the butane cylinder to the burners: flexible tubing (2.5 to 3.0 m (8 to 10 ft) in length,  $7.0 \pm 1.0$  mm ( $1/4 \pm 0.04$  in) I.D.), needle valve, an on-off valve and a cylinder regulator capable of providing a nominal outlet pressure of 2.8 kPa (28 mbar).

NOTE: The following specific items have been found to be satisfactory for the butane gas train: Air Products CP grade, 99.0% purity butane, 20 lb. cylinder; Matheson 2-stage regulator, Model 8-2-510; Matheson 9.0 kPa pressure gauge, P/N 63-3103.



Figure B-1. Meker-Fisher Gas Burner

## **ANNEX C**

### **Test Facility, Exhaust System and Hazards**

#### **Test Facility/Exhaust System**

The test area shall be a room with a volume greater than 20 m<sup>3</sup> (in order to contain sufficient oxygen for testing) or a smaller area equipped with inlet and extraction systems permitting the necessary flow of air. All smoldering tests shall be conducted under appropriate test hoods and/or test cabinets equipped with variable speed exhaust fans or other means of controlling the exhaust flow rates, such as dampers. Airflow rates shall be between 0.02 m/s and 0.2 m/s (4 and 40 ft/min), measured in the locality of the test specimen. Position specimen to provide adequate air around the test specimen without disturbing the burning behavior.

Note 1: These rates of airflow have been shown to provide adequate oxygen without physically disturbing the burning behavior of the ignition source or the specimen.

Note 2: A fume hood with air curtains across the face and zero air velocity at the test locations is recommended. Zero air velocity is indicated by an undisturbed vertical smoke plume of 6 inches.

#### **Hazards**

- There are potential risks associated with running any fire test. It is essential that suitable precautions be taken, which include the provision of breathing apparatus and proper safety equipment.
- Products of combustion can be irritating and dangerous to test personnel. Test personnel must avoid exposure to smoke and gases produced during testing.
- Suitable means of fire extinguishment shall be at hand. When the termination point of the experiment has been reached, the fire is extinguished, if necessary, with carbon dioxide or water. Presence of a back-up fire extinguisher is recommended. It may be difficult to judge when all combustion in a test specimen has ceased due to potential smoldering or burning deep inside the specimen even after extinguishment. Care should be taken that specimens are disposed of only when completely inert.

## Open Flame Barrier Study-Discussion Points

### Responses to Comments Received on Open Flame Barrier Study and the Proposed Small-Scale Test Method

Issue Area	Comment	Response
<b>Lack of Fire Statistics</b>	Furniture Fire Statistics Do Not Support a Need for a New Open Flame Standard.	This comment is outside the scope of this study. The Bureau has committed to conduct a study on emerging fire barrier technologies that can be used in upholstered furniture with an open flame test method.
<b>Full-Scale Test vs. Barrier Test</b>	Rationale for development of a barrier test.	Full-scale fire testing of residential furniture is cost prohibitive. Unlike mattresses there is not a single shape that represents all upholstered furniture much more testing of various prototypes would need to be done. The bench scale barrier test will allow a particular barrier to be used for multiple furniture configurations.
<b>Negative Effects of Barriers</b>	Barriers typically have a negative effect on aesthetics, comfort and cost without any appreciable benefit to user safety.	Phase three, rather than phase two, of this study will explore this issue.
<b>Severity of the Test</b>	The requirements of the proposed test method, as it is described now, is too severe for upholstered furniture for home use.	The full scale test method the Bureau is currently developing is designed to validate the proposed small scale test method and should provide data on this issue.
<b>Ignition Flame Application</b>	Why is the flame applied from underneath in this test?	The flame being located under the test specimen minimizes variation in the flame that can occur when the flame is oriented other than vertical.
<b>The Standard Polyurethane Foam</b>	An open flame test should be tested on a material combination reflecting the actual construction.	This foam was selected for two reasons, 1) it is readily available to the Bureau and 2) the average foam density the Bureau has seen in its compliance tests is 1.55 lb/ft <sup>3</sup> . The standard foam has a density of 1.8 lb/ft <sup>3</sup> . This density is similar; however, this will be noted in the Bureau's findings.
<b>Barrier Thickness</b>	Either all barrier specimens are to be tested with actual thickness, or all specimens should be built up to or reduced to 38 mm.	All barriers shall be tested in their actual thickness. The proposed test method wording has been modified to state this.

<b>Cover Fabric</b>	Cover fabric acting as a barrier.	Agree. If a cover fabric is highly fire resistant (e.g. materials such as 100% wool, leather and others...) and the fabric itself can pass this test, then furniture made of that cover fabric may not need a separate barrier.
<b>Butane Gas</b>	Commercial grade butane can be considered.	Agree. The proposed wording has been modified to reflect the change.
<b>Stockinet Type Materials</b>	How would the method assess these as to prevent sagging or wrinkling tension would need to be maintained?	Gauze like or highly stretchable materials can be tested in the proposed configuration and if they sag (even when held tightly in place) that would be due to the nature of the product and we don't think the test method can or needs to be modified to accommodate for the sagging.
<b>Testing Other Materials</b>	The methodology should allow for the testing of materials, or combinations of materials, in addition to textiles.	Any material or combination of materials that can be used as a barrier can be tested.
<b>Testing Full Furniture Assemblies and Composites</b>	The proposed method should better represent a full furniture assembly to ensure the results can be compared to real-life fire scenarios.	As previously stated, unlike mattresses there is not a single generic shape that represents all upholstered furniture much more testing of various prototypes would need to be done. The bench scale barrier test will allow a particular barrier to be used for multiple furniture configurations.
<b>Variables in Furniture Fire Tests</b>	The proposed test method does not address role of cover fabrics, different fills, different ignition sources, orientations, location and duration of ignition, .....	The proposed test method is not intended to address all aspects and variables in furniture fires. It is only a test for fire barrier materials for use in upholstered furniture. All barrier materials will be tested under the same conditions in order to compare their efficiencies. The full-scale validation tests will demonstrate effectiveness of the standard.
<b>Fire Retardant Chemicals Concerns</b>	Open flame standards pose a hazard to human and ecological health.	The Bureau plans to address this concern in two ways: 1) through testing for the presence of FR chemicals in the barriers and 2) conducting a cost benefit analysis in phase three of the study.
<b>Pass/Fail Criteria</b>	Pass/fail criteria to include: "The material is considered to have failed if the SPUF ignites <u>or</u> there is a visible flame (however brief) observed above the foam."	Agree. The pass/fail criteria have been modified accordingly.

## Agenda Item 14: SB 1019 Compliance Statistics

## SB 1019 LABELING STATISTICS

Samples Received with the SB 1019-Flame Retardant Chemical Statement 01/01/2015 – 01/29/2016			
Month	"NO" Chemicals Checked	Contains Chemicals	No Box Checked
February, 2015	1	1	0
March	2	1	0
April	5	2	0
May	6	0	0
June	9	5	3
July	9	1	1
August	11	4	0
September	3	3	0
October	0	0	0
November	2	0	0
December	15	4	0
January, 2016	12	2	0
<b>Total</b>	75 (73%)	23 (23%)	4 (4%)

Agenda Item 16: Public Comment Period:  
Presentation on TB 133 by Robert Hupe



# Open Flame Regulations and the Furniture Industry – Another Challenge

February 10, 2016  
Robert Hupe

# Agenda

What is TB-133?

Problems with TB-133

Fire Data

Reasons to Withdraw TB-133

# What is TB-133?

Flammability Test  
Procedure for Seating  
Furniture for Use in Public  
Occupancies (January  
1991)

This type of ignition may  
be typical of arson or  
incendiary fires or common  
accidental fires in public  
buildings.

Gas burner placed in the  
seat for 80 seconds.



# Benefits of TB-133 in 2016:

# Problems with TB-133:

- Environmental and Health Concerns with the use of Fire Retardant (FR) Chemicals
- Loss of Comfort and Performance of Furniture with added chemicals and barriers
- More FR chemicals in TB-117-2013 products
- High Cost
- Limits Designs & Fabrics
- The Test is focused on the Seat



# Fires by Occupancy (deaths):

- Residential – 2,696 (96%)
- Storage - 30 (1%)
- **Mercantile, Business – 22 (<1%)**
- Outside or special property – 15 (<1%)
- Six other listed Occupancies are all near zero.
  - Structure Fires by Occupancy 2007-2011 Annual Averages – NFPA (April 2013)

# Residential Deaths:

- Leading heat source for Upholstered Furniture: Smoking Materials (TB-117-2013 seems appropriate!)
- Human Factors Contributing to Fatal Home Fires:
  - Alcohol / Drugs (26%)
  - Asleep (23%)
  - Unsupervised child under 10 (20%)
  - Physically disabled (18%)
  - Mentally disabled (13%)
- The above factors generally not in the Business Office!
  - Home Fires that Began with Upholstered Furniture. NFPA (August 2011)





## Mercantile, Business Deaths (22):

- Motor Vehicle or Boat sales, services, repair (5)
- Specialty Shop (4)
- **Business Office (3 - which is 0.1%)**
- Mercantile, Business, other (2)
- Convenience Store (1)
- Food and beverage sales, grocery store (1)
- Textile, wearing apparel, sales (1)
- Personal service, inc. barber & beauty shops (1)
- Laundry, dry cleaning (1)
- Recreational, hobby, home repair sales, pet store (1)
- General retail, other (1 to 2?)

Would TB-133 make a difference for any of the above??

- Structure Fires by Occupancy 2007-2011 Annual Averages – NFPA (April 2013)



# Examples of Business Office Fires:

- California: “A security and alarm monitoring company employee was using a torch to heat illegal drugs in his second-floor office workstation when he inadvertently ignited combustibles on his desk.”
- Michigan: “A 39-year old man was killed in a cigarette fire in a church. The man ... had been living temporarily in one of the offices. The fire began when a cigarette ignited rubbish in a trash can in a first floor coat room.”

(There are extremely few deaths in Business Offices and the presenter did not find any examples where a chair was involved in a fatality)

- U.S. Structure Fires in Office Properties.  
NFPA (August 2013)

# Reasons to Keep TB-133 in 2016 and beyond:

# Reasons to Withdraw TB-133:

- Commercial Customers do not want FR Chemicals (boycotts)
- Comfort and Performance of Furniture
- Impact on TB-117-2013 products and SB-1019
- Product Costs
- Product Development Time and Costs
- Product Offerings
- Fire Statistics in the commercial / public spaces do not justify the need for TB-133
- Fire Fighters have suggested that extra FR chemicals (toxins) are more of a problem

# What Can You Do for Upholstered Furniture Flammability Safety?

- Insist California should Withdraw TB-133
- Oppose creation of ‘new’ open flame standards
- Do not support a prescriptive ‘barrier’ standard

A smolder standard such as TB-117-2013 should become a national standard for all upholstered furniture!

# Thank You

BIFMA

678 Front Avenue NW, Suite 150

Grand Rapids, MI 49504

(616) 285-3963

[www.bifma.org](http://www.bifma.org)

[dpanning@bifma.org](mailto:dpanning@bifma.org)